

10DWP-Series Australian Double Pole Weatherprotected Power Outlet

This automatically switched unit provides power from caravans to annexes and other similar applications. It is fitted with spring loaded weather-protected flaps marked 'Power Outlet'. Its appearance matches the 435VF15 range of Inlet Sockets.

A weatherprotected flush mounting gasket provided. Mounting flange 93 x

82mm. Mounting centres 70 x 54mm. Base projection 26mm. Cut-out 52mm diameter hole 6mm above horizontal centreline between mounting holes. Active and Neutral terminal bores 5.5mm. Earth 4.8 x 5.2mm. Terminals accommodate 4 x 2.5mm² cables.

Mines and Energy South Australia Approval S/1.

Standard colours are White & Black. Further dimensional informations available.

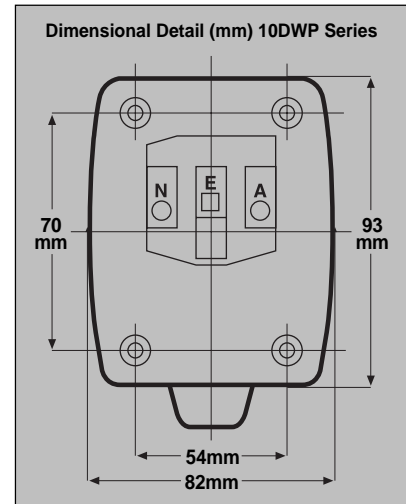

10DWP

Products Available		IP Rating
10DWP	10A 250V Double Pole Automatically Switched Single Outlet, Flush Mounting, White, Black (Gray available).	53
10DWP15	15A 250V Double Pole Automatically Switched Single Outlet, Flush Mounting, White (other colors made to order)	53

Homepage <http://www.BiaGmbH.com> Email info@BiaGmbH.com Document 2308

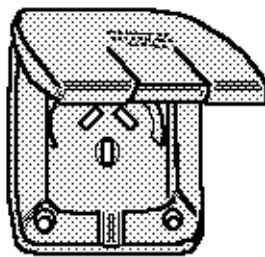

10DWP BK

AUSTRALIAN STANDARD

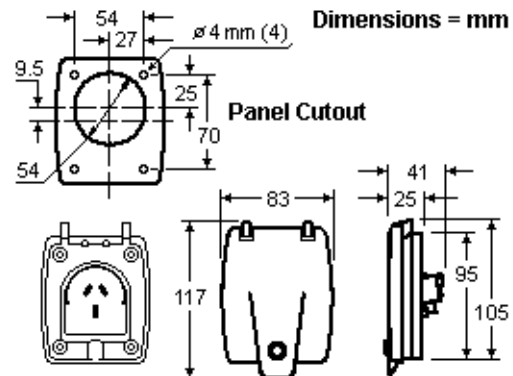

Unterputz Feuchtraum-Steckdosen, grau, Kunststoff, mit Klappdeckel, Klemmen bis 4x2.5mm², IP 53

Weather Protected Flush Mounting Socket Outlets, Plastic, Terminals Accommodate 4x2.5mm², IP 53

Catalog No.	Color	Beschreibung / Description	Wght/ea	UPE/Pack	EDP No
10DWP BK	Black	Flush WP Socket, 10A 250Vac	62g	20	117804
10DWP WE	White	Flush WP Socket, 10A 250Vac	62g	20	117805
10DWP15 WE	White	Flush WP Socket, 15A 250Vac	64g	10	117806

B-I-A GmbH (C) 20.11.02 Telefon (06151) 8786-0 Fax +49-6151-8786-22