



Litestak™ Status Indicator with L.E.D Lamp

Model LSLD

LONG LIFE LIGHT SOURCE

- Available in 24VDC and 120VAC
- Five lens colors
- 100,000 hour, vibration-resistant L.E.D. lamp
- Surface mount and integrated 3/4-inch pipe mount
- UL Listed, cUL Listed, CSA Certified for indoor use
- NEMA 1, IP41 enclosure

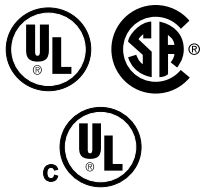

Federal Signal's Litestak™ status indicators are a vertical column of lights that indicate the status of a machine's operating process in a full 360° radius.

The Litestak Model LSLD modular indicator light system allows the user to combine up to five interchangeable lamp units with a base power unit. Modules are sold separately for a truly customized indicator.

Light modules come complete with a 100,000-hour L.E.D. lamp; L.E.D. light output coordinates with the module's impact-resistant polycarbonate lensing. L.E.D. bulbs consume less power, operate at a lower temperature, and are remarkably resistant to vibration — which makes them perfect for use in heavy-duty, high-vibration applications.

L.E.D. lamps are available in five colors — amber, blue, clear, green or red. The standard double-contact bayonet base retrofits into any Federal Signal Litestak unit to replace original incandescent lamps.

An optional Sound Module (Models LSS or LSH) can be added to the top of the Litestak column to create a dual purpose audible/visual status indicating signal. The LSS sound module allows the user to select from 18 tones via a simple dip switch panel. In applications where a single loud tone is all that is necessary, the LSH piezo-electric horn is a perfect audible addition.

Litestak is a versatile system that allows the user to select either steady burn or flash (a flasher is included on the 120VAC unit only). The Litestak base unit can be either surface mount, or 3/4" pipe mount.

Model	Voltage	Operating Current	Mount
LSB ³	24-240VAC/DC	N/A ¹	3/4" Pipe/Surface
LSB ³	120VAC 50/60Hz	N/A ¹	3/4" Pipe/Surface
LSBS ³	24-240VAC/DC	N/A ¹	Surface
LSLD ²	24VDC	0.20 amps	N/A ¹
LSLD ²	120VAC 50/60Hz	0.04 amps	N/A ¹

¹Not Applicable ²Includes lens, lamp and light module. ³Cap kit included.

LITESTAK™ WITH L.E.D. LAMP (LSLD)

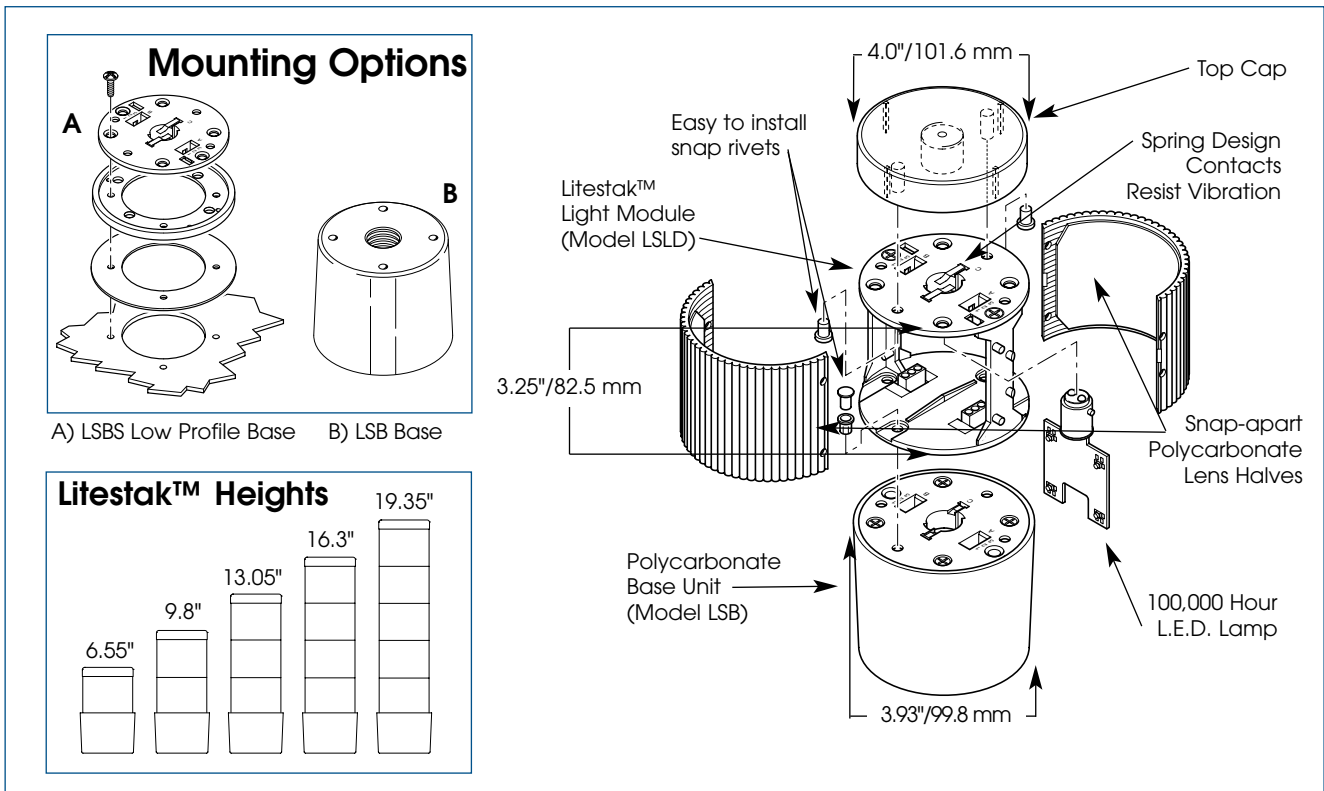

SPECIFICATIONS

Lamp Life*:	100,000 Hours	100,000 Hours
Lamp Style:	L.E.D.	L.E.D.
Operating Temperature:	-32°F to 120°F	-36°C to 49°C
Net Weight, LSLD:	0.45 lbs.	0.2 kg
Shipping Weight, LSLD:	0.70 lbs.	0.32 kg
LSLD Height:	3.25"	82.5 mm
LSB Height:	3.3"	83.8 mm
LSLD Diameter:	3.93"	99.82 mm
LSB Diameter:	3.93"	99.82 mm

* Optimal hours under ideal conditions.

HOW TO ORDER

- Specify model, voltage and color of light modules
- Specify model and voltage of base unit:
LSB for 3/4" pipe or surface mount
LSBS for low-profile surface mount
- Specify optional sound module
(doc. # 5106 or piezo horn doc. # 5107)

REPLACEMENT PARTS

Description	Part Number	Description	Part Number
Lens Kit, Amber	K8447014A-02	L.E.D. Lamp, Amber 24VDC	LED-024ASB
Lens Kit, Blue	K8447014A-04	L.E.D. Lamp, Blue 24VDC	LED-024BSB
Lens Kit, Clear	K8447014A-05	L.E.D. Lamp, Clear 24VDC	LED-024CSB
Lens Kit, Green	K8447014A-01	L.E.D. Lamp, Green 24VDC	LED-024GSB
Lens Kit, Red	K8447014A-03	L.E.D. Lamp, Red 24VDC	LED-024RSB
Lens Kit, Black-out (1/2 lens)	K8447014A-06	L.E.D. Lamp, Amber 120VAC	LED-120ASB
Flasher (24VDC)	K8285237A	L.E.D. Lamp, Blue 120VAC	LED-120BSB
Flasher (120VAC)	K8285239A	L.E.D. Lamp, Clear 120VAC	LED-120CSB
Cap Kit	K8447009E	L.E.D. Lamp, Green 120VAC	LED-120GSB
Snap Rivets, 50 pieces	K7099A112A-01	L.E.D. Lamp, Red 120VAC	LED-120RSB