



Litestak™ Sound Module

Model LSS

ADD SOUND TO A FEDERAL SIGNAL LITESTAK™

- Modular unit fits on top of any Litestak™ configuration
- Select one of 18 tones
- Available in 24VDC and 120VAC
- Capable of outputs between 59-69dB @ 10' (69-79dB @ 1m)
- UL Listed, CSA Certified for indoor use
- NEMA 1, IP20 enclosure



The Federal Signal Litestak™ Sound Module is a microprocessor-based audible signaling device. The model LSS can be used as a stand-alone audible device or combined with the Federal Signal Litestak light modules to create an audible/visual signal.

The sound module contains a microprocessor-based tone generator and an integrated speaker which produces one of 18 tones. Select tones by setting five, 2-position DIP-switches. The sound module can work as a stand-alone audible signal when plugged into the Model LSBS Low Profile Surface Mount Base or Model LSB Pipe Mount Base.

The Model LSS can be combined with any Litestak light module configuration of up to four colors. Controlling the sound module is done via the wires normally used for the clear light module. The sound module always occupies the top module position in a Litestak tower.

Ideal applications for the LSS include environments where the ambient noise is not extreme – assembly lines, conveyor systems, automated lines, instrument panels and workshops.

LSS is UL (Underwriters Laboratories) Listed and CSA (Canadian Standards Association) Certified. It also meets NEMA (National Electrical Manufacturers Association) Type 1 requirements, and is constructed to IP20.

Federal Signal's Litestak Sound Module allows the user to add a distinctive audible signal to a Litestak Status Indicator.

Model	Voltage	Operating Current	dB Output
LSS	24VDC	0.17 amps	See Chart
LSS	120VAC	0.07 amps	on next Page

LITESTAK™ SOUND MODULE (LSS)

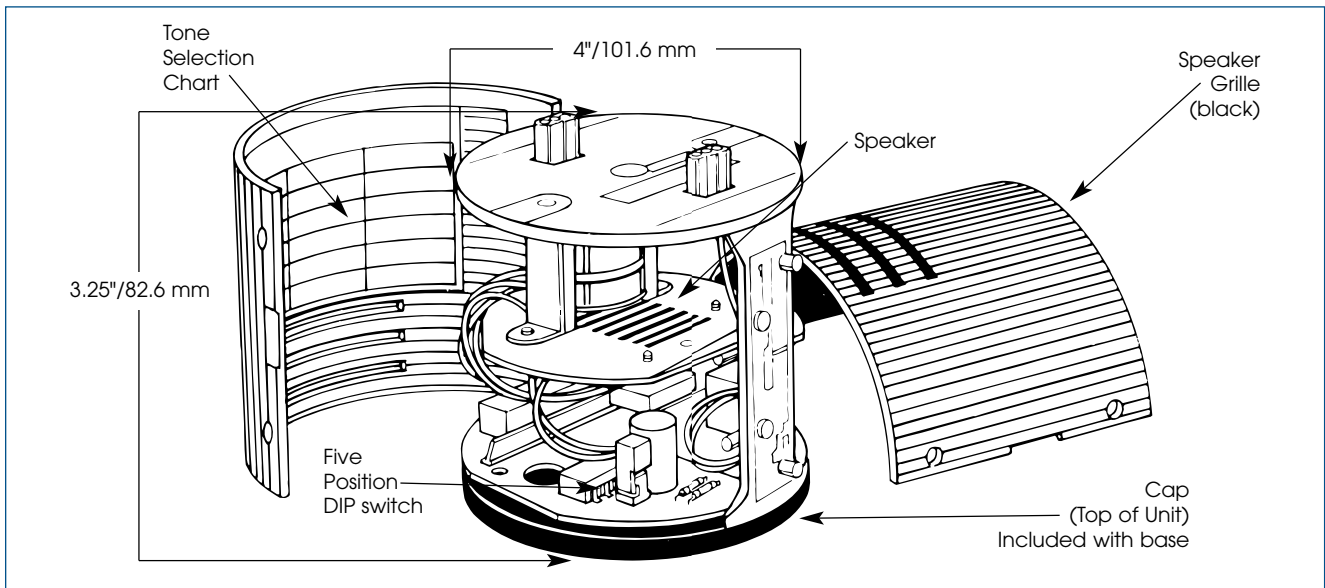

AVAILABLE TONES

Model	Name	Description	Frequency	Rep. Rate	dBA @ 10'/1m
TM1	Wail	Conventional Siren	560-1055Hz	11 cycles/min.	68.8 / 78.8
TM2	Yelp	Rapid Siren	560-1055Hz	3.3 cycles/min.	67.6 / 77.6
TM3	Hi-Lo	Alternating High & Low	Low: 561Hz High: 760Hz	50 cycles/min.	68.3 / 78.3
TM4	Bell	Bell, struck rapidly	801Hz	50 cycles/min.	59.0 / 69.0
TM5	Yeow	Descending high to low, repeated	Low: 545Hz High: 1295Hz	36 cycles/min.	67.8 / 77.8
TM6	Horn	Steady Horn	470Hz	Continuous	61.0 / 71.0
TM7	Beep	Slow intermittent horn	470Hz	50 cycles/min.	59.6 / 69.6
TM8	Stutter	Rapid intermmitent horn	470Hz	5 cycles/sec.	59.4 / 69.4
TM9	Slow Whoop	Slow ascending low to high, repeated	Low: 424Hz High: 1164Hz	15 cycles/min.	66.5 / 76.5
TM10	Gradual Horn	Steady hirn, gradually increasing volume	514Hz	Continuous	62.3 / 72.3
TM11	Temp. Slow Whoop	NFPA' coded slow whoop	Low: 424Hz High: 774Hz	15 cycles/min.	65.2 / 75.2
TM12	Westminster Chime	Westminster Chime	Musical tone	1 cycle; 8 notes	63.4 / 73.4
TM13	Evac./Radiation	Amplitude modulated horn	479Hz	4.3 cycles/sec.	61.7 / 71.7
TM14	Air Horn	Steady horn	Low: 400Hz High: 800Hz	Continuous	66.2 / 76.2
TM15	Chime	Single strike chime	Musical tone	49 cycles/min.	60.6 / 70.6
TM16	Phaser	Rapid siren	600-1200Hz	15 cycles/sec.	63.7 / 73.7
TM17	Alternating Hi-Lo	Alternating High & Low	Low: 363Hz High: 518Hz	60 cycles/min.	63.8 / 73.8
TM18	Warble	Extremely rapid siren	560-1055Hz	63 cycles/sec.	67.1 / 77.1

SPECIFICATIONS

Operating Temperature:	32°F to 120°F	0°C to 49°C
Net Weight:	24VDC 0.60 lbs.	0.3 kg
	120VAC 0.90 lbs.	0.4 kg
Shipping Weight:	24VDC 0.80 lbs.	0.4 kg
	120VAC 1.10 lbs.	0.5 kg
Height:	3.25"	82.6 mm
Diameter:	3.93"	99.8 mm
Operating Current:	24VDC 0.17 amps	0.17 amps
	120VAC 0.07 amps	0.07 amps

HOW TO ORDER

- Specify model and voltage of sound module (base required, [doc. # 5104](#))

REPLACEMENT PARTS

Description	Part Number
Grille, Black	K8447014A-07
Snap Rivets, 50 pieces	K7099A112A-01