

Model 151XST

Hazardous Location Warning Light

Rugged Design for use in Hazardous Locations

- Available in 12-24VDC, 120VAC and 240VAC
- Six dome colors
- 10,000-hour high-intensity strobe
- 3/4-inch pipe mount
- Dome guard included
- UL and cUL Listed, CSA Certified for indoor/outdoor use
- Type 4X, IP66 enclosure
- Marine Rated



Catalog Number	Description	Operating Current	Flash Rate/Minute	Candlepower Peak ¹	ECP ²	Wght/ea
151XST-012-024*	Strobe, 12-24VDC, hazardous location	1.3-0.60 amps	80	520,000	165	1725 g
151XST-120*	Strobe, 120VAC 50/60Hz, hazardous location	0.32 amps	80	520,000	165	1725 g
151XST-240*	Strobe, 240VAC 50/60Hz, hazardous location	0.16 amps	80	520,000	165	1725 g

* Add color option to catalog number: A = Amber, B = Blue, C = Clear, G = Green, M = Magenta, R = Red

¹ Peak candlepower is the maximum light intensity generated by a flashing light during its light pulse

² ECP (Effective Candlepower) is the intensity that would appear to an observer if the light were burning steadily

Model 151XST hazardous location strobe light provides 80 high-intensity flashes per minute. This warning light is available in 12-24VDC, 120VAC and 240VAC, 50/60Hz.

The Model 151XST strobe light is UL Listed and CSA Certified for Class I, Division 2, Groups A, B, C and D; Class II, Division 1, Groups E, F and G; and Class III.

The 151XST meets Type 4X water-tight, dust-tight, and corrosion resistant requirements; constructed to IP66. This hazardous location warning light has an aluminum base, coated for corrosion resistance that is ready for mounting on a 3/4-inch pipe. The Dome Guard (included) fits over the glass dome to protect it against accidental collision with moving equipment, such as forklifts.

The 151XST has an effective candlepower (ECP) of 165 and a 520,000 peak candlepower. It is available in six dome colors, including amber, blue, clear, green and red (magenta upon request).

The rugged 151XST strobe warning light is specifically designed for hazardous locations or corrosive environments where a very bright visual signal is required.

This warning light can be used for plant evacuation or other communication needs.

To learn more about B-I-A please visit us at our
WEB site: www.BiaGmbH.com



HAZARDOUS LOCATION STROBE LIGHT (151XST)

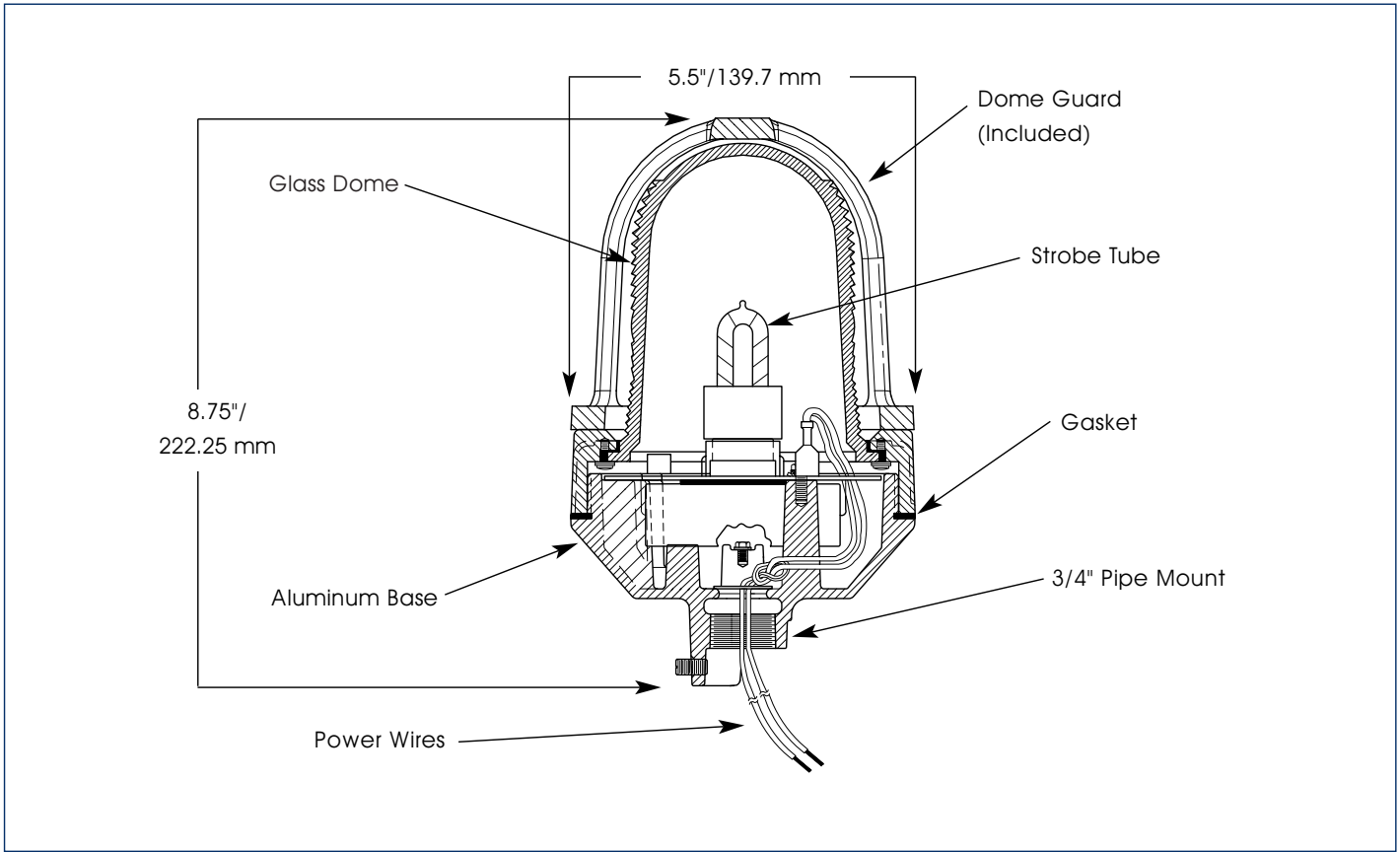

SPECIFICATIONS

Lamp Life*:	10,000 Hours	10,000 Hours
Lamp Style	Strobe	Strobe
Operating Temperature	-31°F to 150°F	-35°C to 66°C
Net Weight:	3.8 lbs.	1.7 kg
Shipping Weight:	4.5 lbs.	2.0 kg
Height:	8.75"	222.25 mm
Diameter:	5.5"	139.7 mm

* Optimal hours under ideal conditions.

HOW TO ORDER

- Specify model, voltage and color

REPLACEMENT PARTS

<u>Description</u>	<u>Part Number</u>	<u>Description</u>	<u>Part Number</u>
<u>Series C Dome and Ring Assembly*</u>			
Dome & Ring Assembly, Amber	K8449078C-01	PC Assembly, 12-24VDC	K2001173A
Dome & Ring Assembly, Blue	K8449078C-02	PC Assembly, 120VAC	K2001071B
Dome & Ring Assembly, Clear	K8449078C-04	PC Assembly, 240VAC	K2001071B-01
Dome & Ring Assembly, Green	K8449078C-03	Strobe Tube	K149122B
Dome & Ring Assembly, Red	K8449078C	Dome Gaskets	K8449080B
Dome & Ring Assembly, Magenta	K8449078C-05	Guard	K8449090B

* Call the factory for Series A and B part numbers.