



Strobe Combination Audible/Visual Warning Signal

Model 400ST

AUDIBLE AND VISUAL WARNING IN A SINGLE VERSATILE UNIT

- Available in 120VAC
- Five dome colors
- 10,000 hour strobe tube
- Wall mount
- UL Listed, CSA Certified for indoor/outdoor use
- NEMA 3R, IP43 enclosure

Federal Signal's Model 400ST audible/visual signal combines the effective warning of a strobe light with a Federal Signal Model 350 horn (sold separately).

The Model 400ST includes a fresnel lens, providing 360-degree flash coverage. Its strobe tube produces bright, high-intensity flashes at 400 effective candlepower at 75 flashes per minute.

Available in five dome colors: amber, blue, clear, green and red.

The Model 400ST is ideal for use wherever both audible and visual warning signals are needed. This rugged unit is excellent for industrial use and adaptable to most in-plant signaling needs.

A sleek housing design makes the Model 400ST suitable for use in institutional or non-industrial settings requiring an audible/visual alarm system, where heavy-duty industrial equipment might not be appropriate.



Model	Voltage	Operating Current	Flash Rate/Minute	Candlepower Peak ¹	ECP ²	Mount
400ST	120VAC 50/60Hz	0.25 amps	75	900,000	400	Wall/Surface

¹ Peak candlepower is the maximum light intensity generated by a flashing light during its light pulse

² ECP (Effective Candlepower) is the intensity that would appear to an observer if the light were burning steadily

STROBE AUDIBLE/VISUAL WARNING SIGNAL (400ST)

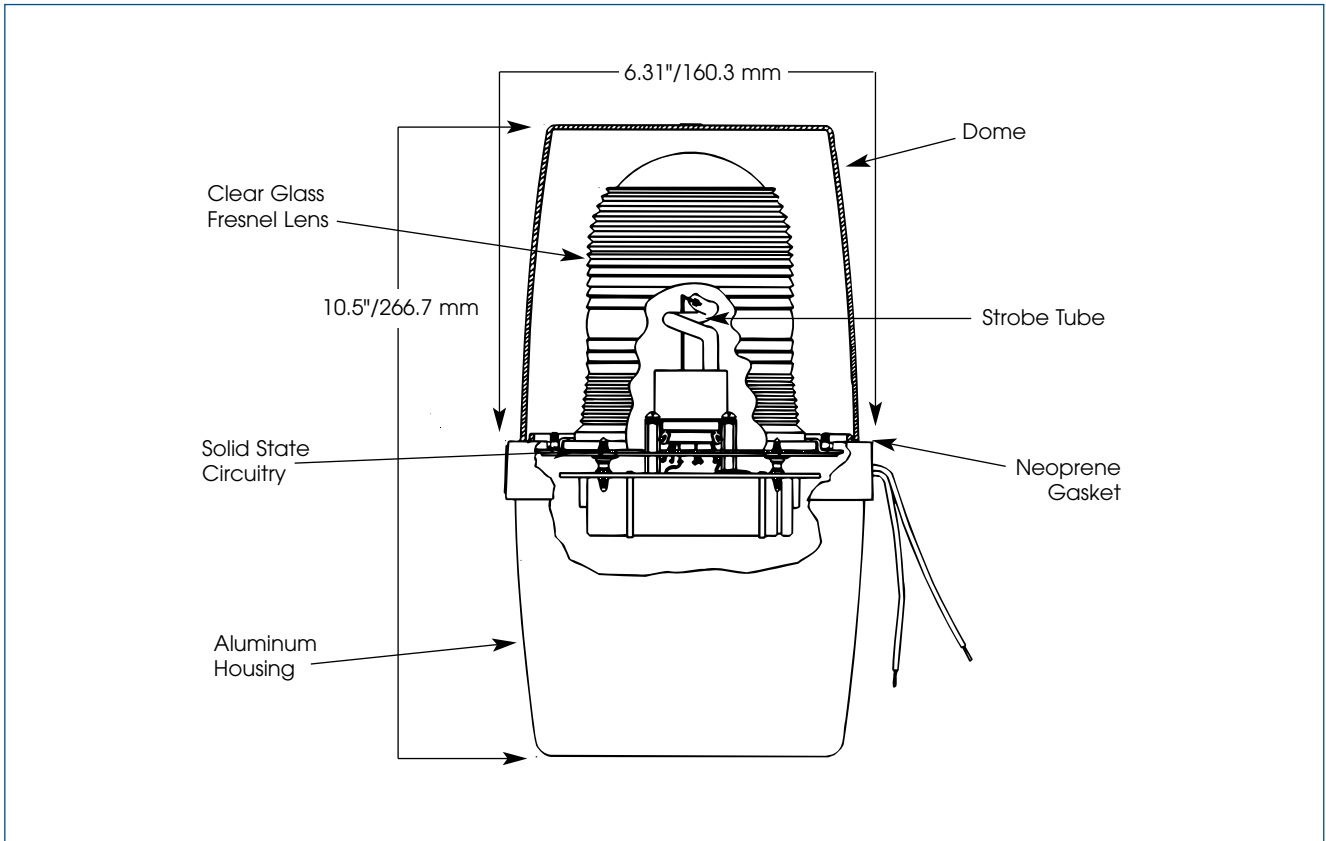

SPECIFICATIONS

Lamp Life*:	10,000 hours	10,000 hours
Lamp Style:	Strobe	Strobe
Operating Temperature:	-31°F to 150°F	-35°C to 66°C
Net Weight:	4.5 lbs.	2.0 kg
Shipping Weight:	5.1 lbs.	2.3 kg
Height:	10.5"	266.7 mm
Diameter:	6.31"	160.3 mm

* Optimal hours under ideal conditions.

HOW TO ORDER

- Specify model, voltage and color
- Specify options:
Audible signaling with [horn \(350\)](#)
and mounting kit (400HMK-AC)

REPLACEMENT PARTS

Description	Part Number
Exterior Dome, Amber	K8547C001A-04
Exterior Dome, Blue	K8547C001A-02
Exterior Dome, Clear	K8547C001A-05
Exterior Dome, Green	K8547C001A-03
Exterior Dome, Red	K8547C001A-01
Interior Fresnel Lens, Clear	K8248C004E-04
Strobe Tube, 120VAC	K8107178A
PC Assembly, 120VAC	K200D825C