

Fireball® 24-HI Supervised Hearing Impaired Strobe Warning Light

Model FB24STHI

LIGHT DUTY STROBE LIGHT

- Available in 12-24VDC, 120VAC and 240VAC
- Four wires and supervisory diode
- Clear dome
- 10,000 hour strobe tube
- Integrated 1/2" pipe mount and surface mount
- UL Listed, CSA Certified for indoor/outdoor use
- UL1971 Listed
- NEMA 4X, IP66 enclosure

Federal Signal's brightest and most compact strobe light, this Supervised FireBall® emits a powerful "lightning bolt" flash of light. Approximately five inches tall and four inches in diameter and rated at 300 effective candlepower, the FB24STHI is economical and effective. The Fireball is available in 12-24VDC, 120VAC and 240VAC, this model is UL Listed (Underwriters Laboratories) and CSA Certified (Canadian Standards Association).

The FB24STHI features a clear dome that twists off easily for quick dome and lamp replacements. The newly redesigned base features an integrated 1/2" pipe mount boss as well as the three holes required for surface mount configurations. Black epoxy paint is electrostatically applied to the base for superior corrosion resistance. The Fireball dome and base design provides a water-tight, dust-tight and corrosion resistant NEMA 4X rating.

The Fireball FB24STHI contains a supervisory diode and four wire leads, for use in fire alarm applications. This strobe is also UL 1971 listed, for hearing impaired applications.



Model	Voltage	Operating Current	Flash Rate/Minute	Candlepower Peak ¹	ECP ²	Mount
FB24STHI	12-24 VDC	1.70-0.70 amps	80	1,000,000	300	1/2" Pipe/Surface
FB24STHI	120VAC 50/60Hz	0.25 amps	90	1,000,000	300	1/2" Pipe/Surface
FB24STHI	240VAC 50/60Hz	0.20 amps	90	1,000,000	300	1/2" Pipe/Surface

¹ Peak candlepower is the maximum light intensity generated by a flashing light during its light pulse
² ECP (Effective Candlepower) is the intensity that would appear to an observer if the light were burning steadily

FIREBALL® STROBE WARNING LIGHT (FB24STHI)

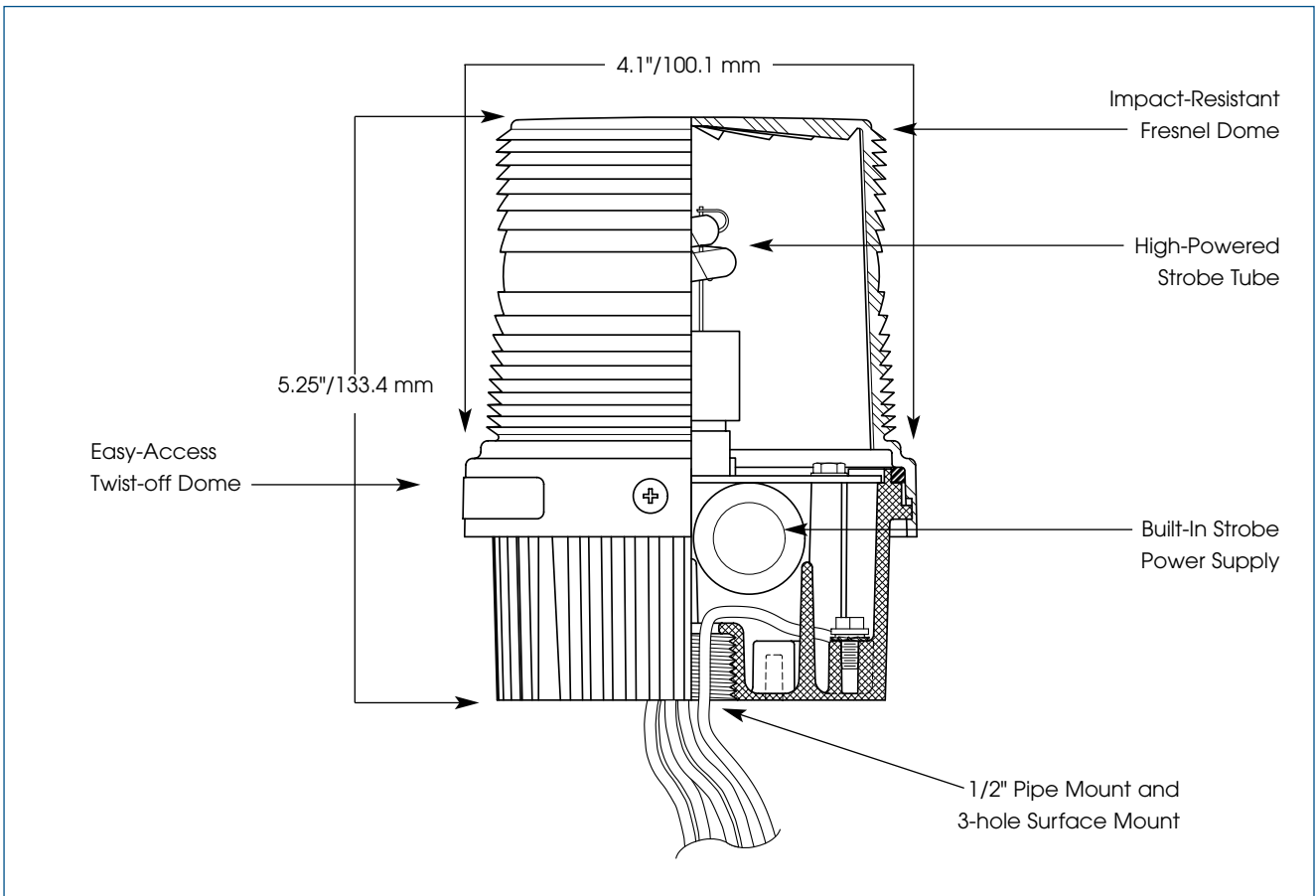

SPECIFICATIONS

Lamp Life*:	10,000 Hours	10,000 Hours
Operating Temperature:	-31°F to 150°F	-35°C to 66°C
Lamp Style:	Strobe	Strobe
Net Weight:	1.45 lbs.	0.7 kg
Shipping Weight:	1.7 lbs.	0.8 kg
Height:	5.25"	133.4
Diameter:	3.94"	100.1

* Optimal hours under ideal conditions.

HOW TO ORDER

- Specify model, voltage and color
- Specify options:
Corner Bracket (LCMB2)*
Wall Bracket (LWMB2)*

* Brackets not NEMA 4X rated.

REPLACEMENT PARTS

<u>Description</u>	<u>Part Number</u>	<u>Description</u>	<u>Part Number</u>
PC Assembly, 12-24VDC	K2001202B	Strobe Tube	K8107177A
PC Assembly, 120VAC	K200D866G	Dome, Clear	K8550320A-02
PC Assembly, 240VAC	K200D866G-01		