

LIFESTAR

RESIDUAL CURRENT DEVICES

Lifestar RCDs comply fully with BS EN 61008 to Type A and Type AC classification.



Pulsating dc (half wave rectified) waveform



Pulsating dc (chopped) waveform



Pulsating dc (chopped) waveform with a constant dc component

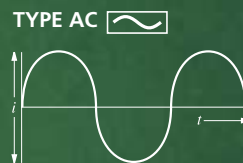

Normal ac waveform

Lifestar offers you the protection of Residual Current Devices (RCDs) for any industrial, commercial or domestic application. RCDs rated from 13A to 100A are available in sensitivities from 10mA to 300mA providing safe, secure protection against fire or shock risks caused by earth fault currents.

Suitable for screw fixing or DIN rail mounting.

Wide range of enclosures available for separately mounting RCCBs, MCBs and RCBOs.





13A SAFETY SOCKETS WITH RCD PROTECTION

The Lifestar safety socket is available in 2 gang versions with 30mA sensitivity, enabling products to be precisely matched to specific applications. All safety sockets incorporate pulsating dc fault current protection (Type A operation).

- Double pole operation, 3mm contact gap.
- Trip free mechanism for automatic disconnection of supply.
- Enables mounting in standard 25mm deep box (moulded variant).
- Mechanical indication of contact position.
- Unique labyrinth switch design minimises visible arc flash and prevents front access to live parts.
- Surface mounted units supplied with Birch Grey mounting box.
- Interior units available for mounting into OEM equipment.
- Comply with BS 7288.
- RCD sockets are all passive control electromechanical operation and will not trip on loss of mains supply.



MOULDED

4406/A03

2 gang switched with neon indicator. 30mA tripping current

Dimensions: 146mm x 86mm

Mounting boxes: 9048 surface, SB665 flush galv.
or SB629 dry lining

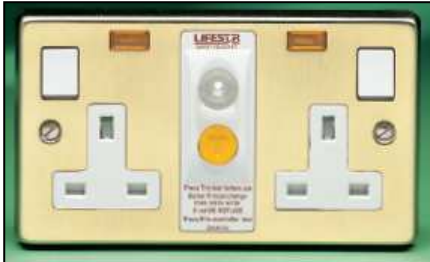

FLUSH METAL PLATE*

4416/A03_ _*

2 gang switched with neon indicator, 30mA tripping current

Dimensions: 146mm x 86mm

Mounting boxes: 9048 surface, SB665 flush galv.
or SB629 dry lining

(4416/A03BZ shown)

* Metal plate variants available in Satin Chrome (SC), Bronze (BZ) and Polished Stainless Steel (PSS) – Add suffix to List No. eg 4416/A03SC. For further specification details of finishes contact sales office.



INTERIOR

4416/A103

2 gang switched with neon indicator, 30mA tripping current



SURFACE METALCLAD

4426/A03BG

2 gang switched with neon indicator, 30mA tripping current

Dimensions: 142mm x 82mm x 44mm

For boxes less knockouts contact sales office.



FLUSH METALCLAD

4416/A03BG

2 gang switched with neon indicator, 30mA tripping current

Dimensions: 146mm x 86mm

Mounting boxes: 9223/BG surface, SB625 flush galv.
or SB629 dry lining

All complete with two earth terminals to enable installation to comply with section 607 (wiring regulations).



228/030

RESIDUAL CURRENT CIRCUIT BREAKERS

TYPE AC 		SENSITIVITY		
2 POLE				
CURRENT RATING (A)	MODULES	30mA	100mA	300mA
32	2	223/030	-	-
40	2	224/030	224/100	224/300
63	2	226/030	226/100	226/300
80	2	228/030	228/100	-
100	2	221/030	221/100	221/300



246/030

4 POLE				
CURRENT RATING (A)	MODULES	30mA	100mA	300mA
32	4	243/030	-	-
40	4	244/030	244/100	244/300
63	4	246/030	246/100	246/300
100	4	241/030	241/100	241/300

TIME DELAY - RCCB

TYPE AC 		SENSITIVITY	
2 POLE			
CURRENT RATING (A)	MODULES	100mA	
100	2	221/100TD	
4 POLE			
CURRENT RATING (A)	MODULES	100mA	
100	4	241/100TD	



221/100TD

241/100TD



RESIDUAL CURRENT CIRCUIT BREAKERS

TYPE A

SENSITIVITY

2 POLE

CURRENT RATING (A)	MODULES	10mA	30mA
16	2	216/A010	-
32	2	223/A010	-
40	2	-	224/A030
63	2	-	226/A030
80	2	-	228/A030
100	2	-	221/A030

4 POLE

CURRENT RATING (A)	MODULES	10mA	30mA
40	4	-	244/A030
63	4	-	246/A030
100	4	-	241/A030

These units are not interchangeable with the RCCBs now available in the Starbreaker range

- BS EN 61008; IEC 1008.
- Terminal capacities: – 50mm².



MODULAR ENCLOSURES

3 MODULE

DESCRIPTION	LIST No
General purpose enclosure (IP20)	744/3

- Complete with DIN rail.
- Features sealable cover.
- Supplied with cut-out of 2 module size.
- Converts to 3 module by removing half blanks.

All purpose enclosure (IP65)	CBE/3
------------------------------	--------------

- Complete with DIN rail.
- Features sealable cover and hinged protective cover.
- Polycarbonate construction.
- Accessories available.
- Self-adhesive way label provided.

Note

Max cable capacity 10mm². For increased cable sizes use 4 module enclosure

*List No. **CBE/4** (up to 25mm²).*

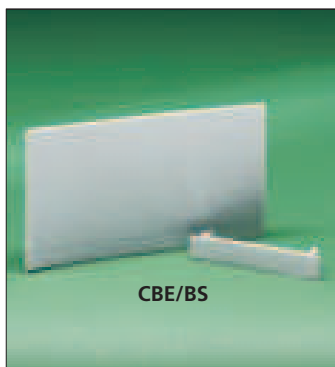

4 MODULE

DESCRIPTION	LIST No
General purpose enclosure (IP20)	744/4
<ul style="list-style-type: none"> ● Complete with DIN rail and earth bar. ● Features sealable cover. 	
All purpose enclosure (IP65)	CBE/4
<ul style="list-style-type: none"> ● Suitable for all ratings. ● Complete with DIN rail. ● Features sealable cover and hinged protective cover. ● Polycarbonate construction. ● Accessories available. ● Self-adhesive way label provided. 	
Fabricated steel enclosure (IP20)	844/4
<ul style="list-style-type: none"> ● Suitable for all ratings. ● Complete with DIN rail and earth terminal. ● Supplied with blank plate for converting to 3 module opening. 	

ACCESSORIES FOR ALL PURPOSE ENCLOSURES

EARTH TERMINAL	LIST No
5 way, 3 module	CBE3/EK
7 way, 4 module	CBE4/EK
NEUTRAL TERMINAL	
5 way, 3 module	CBE3/NK
7 way, 4 module	CBE4/NK
Blanking strip	CBE/BS
External fixing bracket	ME/FB

RCD COVER MODULE

	PACK QTY	
2 gang RCD cover with neon assembly and RCD mounting cradle	2	9570/2

Should be assembled in deep enclosures.

- Suitable for any 2 module RCD from the Lifestar range

Polycarbonate is a highly durable material which is ideal for use in most environments, however seek advice before installing in environments where chemicals or harsh cleaners are likely to be used.

RCDs – STARBREAKER & LIFESTAR

SPECIFICATION

- BS EN 61008 RCCBs
- BS EN 61009 RCBOs
- BS 7288 SRCDs
- Range of current ratings 13–100A
- Range of sensitivities 10–300mA
- Pole configurations DP and TP & N
DP SRCD – 230V
- Voltage ratings 1 Module SP & N – 230V Other voltage ratings available on request
- Frequency rating 50Hz
- Tripping principle employed 2 & 3 Module DP – 230V
4 Module TP & N – 400V
Electro-mechanical (3 & 4 Module)
Electronic (1 Module)



OPERATION

The RCD employs the current balance principle which involves the supply conductors to the load (phase and neutral) being wound onto a common transformer core to form the primary windings. The secondary winding of the current transformer is then connected to the trip mechanism, either an electro-magnetic relay in the case of 2, 3 and 4 module RCCBs or an electronic relay in the case of Starbreaker RCBOs, and Lifestar SRCDs. Under healthy circuit conditions, the current in the phase conductor is equal to the current in the neutral and the vector sum of the current is zero. In the event of an earth fault, an amount of current will flow to earth, creating an out of balance situation in the transformer assembly. This out of balance is detected by the secondary winding of the transformer and at a pre-determined level of out of balance will activate the trip mechanism.

Single phase and neutral or three phase and neutral units (suitable for 3 or 4 wire systems) are available, the latter being suitable for balanced or unbalanced 3 phase loads.

The RCD trip mechanism will operate at a residual current of between 50–100% of its rated tripping current (sensitivity).

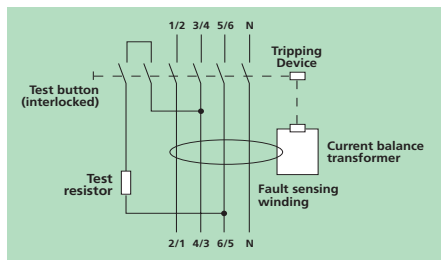

RCD circuit diagram (four pole)

Note
Exposed installation metal work must be earthed.
When used on 3 wire 230V systems a link should be connected between 5/6 and N.

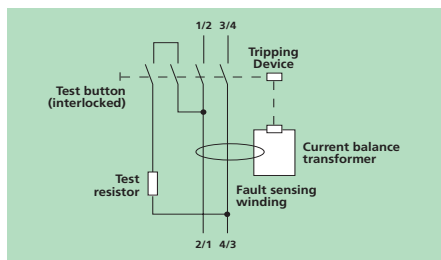

RCD circuit diagram (two pole)

Note
Exposed installation metal work must be earthed.

TEST BUTTON

A test button is provided on all RCDs to enable the operation of the device to be checked.

It is recommended that an RCD is tested at least quarterly. (See BS 7671 Regulation 514-12-02).

TERMINAL CAPACITIES

Lifestar RCCBs	50mm ²	Lifestar SRCDs	3 x 2.5mm ²
			3 x 4mm ²
			2 x 6mm ²

Starbreaker RCBOs 10mm²

APPLICATIONS

Residual Current Devices (RCDs) may be required for one of two main reasons:

(a) to ensure the compliance of an installation with BS 7671, formerly the IEE Wiring Regulations.

An RCD may be installed to meet the requirements of Regulation 413-02-15 where a high earth fault loop impedance disqualifies the use of overcurrent protection devices as a means of providing protection against indirect contact. To comply with Regulation 413-02-16 the earth fault loop impedance in ohms multiplied by the rated tripping current of the RCD in amperes must not exceed 50. With the RCD having a sensitivity of 30mA, the maximum permissible earth fault loop impedance is calculated as follows:

$$Z_s \text{ (max)} = 50 / 0.03 = 1666 \text{ Ohms}$$

Rated tripping current of RCD	Max permissible earth fault loop impedance
30mA	1666 Ohms
100mA	500 Ohms
300mA	166 Ohms

(b) to provide a higher level of protection than that given by direct earthing, against fire or shock risks caused by earth leakage currents.

Overcurrent protection devices cannot detect earth fault currents below their operating current. If they are the only means of earth fault protection, it is possible for sufficient earth fault current to flow undetected to constitute a fire risk.

By using an RCD, the flow of the sustained earth fault current, above the tripping current of the RCD, is prevented. The shock risk associated with these earth fault currents is also greatly reduced.

To provide complete personnel protection, a high sensitivity RCD to a Type A classification with a maximum tripping current of 30mA should be used. This is particularly important with portable appliances where there is a danger of losing earth continuity due to damage or fatigue.

Residual current devices are completely selective in their operation. They are unaffected by parallel earth paths and are thus ideally suitable for the protection of installations in modern high density dwellings or office blocks. They are virtually tamperproof and provide a predetermined level of protection. Even if earthing conditions deteriorate substantially, they will continue to provide a higher level of protection than would have been given by direct earthing. Starbreaker 100A plug in rcd's are recommended for use in larger capacity enclosures, for further advice consult our Technical Department.

SENSITIVITIES

The choice of RCD depends upon the application of the level of protection required.

300mA provide the means to achieve compliance with BS 7671 in conditions of poor earth loop impedance and also give a good level of fire risk protection.

100mA provide the means to achieve compliance with BS 7671, a high level of fire risk protection and a degree of indirect shock risk protection.

30mA for use where a higher level of protection is required, with portable equipment or equipment used in hazardous conditions. Regulation 471-16-01 of BS 7671 indicates that where a socket outlet may reasonably be expected to supply equipment to be used outside the equipotential zone, protection shall be afforded by a residual current device having a rated residual operating current not exceeding 30mA.

Regulation 471-16-02 also contains a requirement for circuits supplying portable equipment outdoors supplied other than through a socket outlet.

10mA provide a higher level of personal protection, for use in sensitive areas such as laboratories, schools and workshops where potential hazards exist from electrical faults caused through misuse, accidental damage or failure of electrical appliances.

TRANSIENT EARTH LEAKAGE CURRENTS

All residual current devices incorporate a high level of immunity to tripping when subjected to transient earth leakage currents.

Such transients can occur when there is a significant level of capacitance to earth as can result from cable capacitance (particularly MICC) or RF filter networks. RCDs are therefore less susceptible to nuisance tripping due to transient earth leakage currents.

APPROXIMATE DIMENSIONS (mm)

13A 2 GANG SRCD (SAFETY SOCKET)

List No	A	B	C	D	E	F	G	H
4416/A10	120.6	79.5	28.45	14.2	38.8	38.4	72.8	27.3

	J	K	L	M	N	O	P	Q
	20.85	113.1	12.9	13.9	32.7	63.5	7.4	14.5

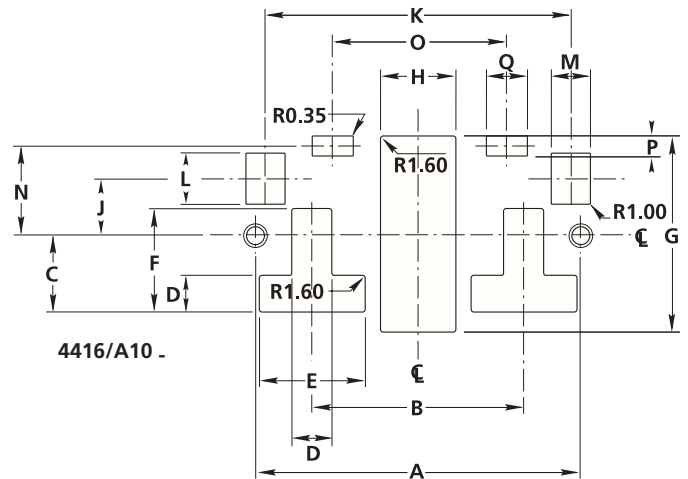

2 MODULE RESIDUAL CURRENT CIRCUIT BREAKERS

List No	A	B	C
223/A010	90	35	75
224/ ---, 226/ ---, 228/ ---	90	35	75
224/A ---, 226/A ---, 228/A ---	90	35	75

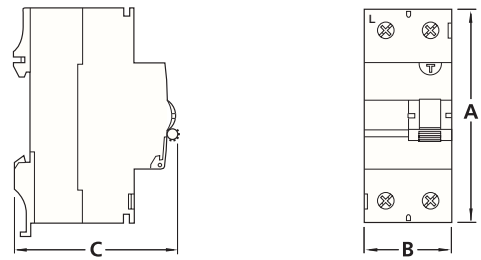

4 MODULE RESIDUAL CURRENT CIRCUIT BREAKERS

List No	A	B	C
244/ ---, 246/ ---, 241/ ---	90	70	75
244/A ---, 246/A ---, 241/A ---	90	70	75

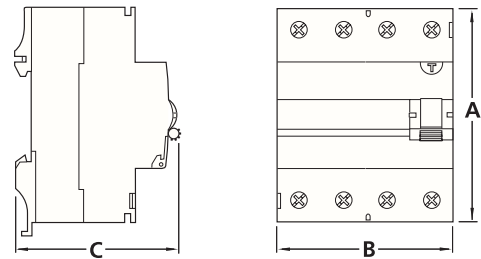

2 MODULE RCBOs (MCB/RCDs)

List No	A	B	*C	D	E
6132/0 . 0	87	36	75	45	50

* Allow 4mm for dolly clearance.

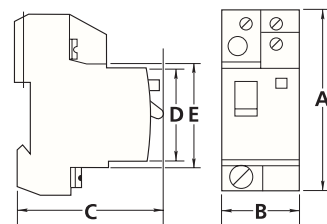

APPROXIMATE DIMENSIONS (mm)

3 MODULE GENERAL PURPOSE ENCLOSURE IP20

List No	A	B	*C	D	E
744/3	150	60	89	68	38

* Allow 4mm for dolly clearance.

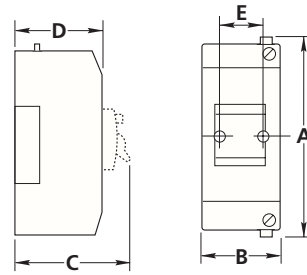

3 MODULE ALL-PURPOSE ENCLOSURE IP65

List No	A	B	C	D	E	F	G
CBE3	160	85	114	140	65	69	96

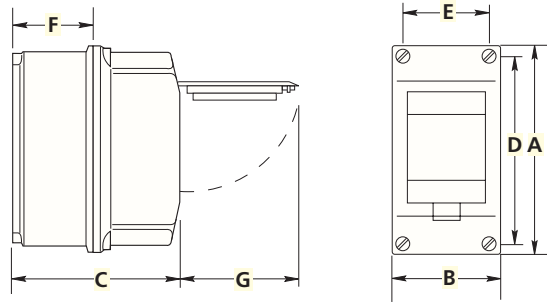

4 MODULE GENERAL PURPOSE ENCLOSURES IP20

List No	A	B	*C	D	E
744/4	150	77	105	68	56

* Allow 4mm for dolly clearance.

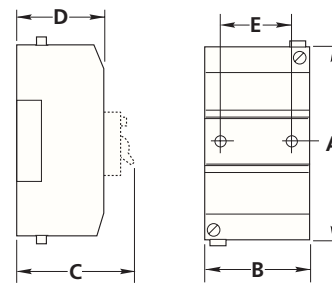

4 MODULE ALL-PURPOSE ENCLOSURE IP65

List No	A	B	C	D	E	F	G
CBE4	160	110	114	140	90	69	96

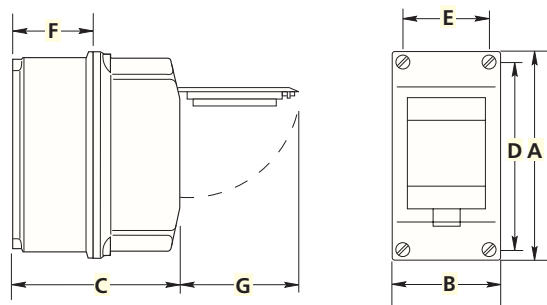

4 MODULE FABRICATED STEEL ENCLOSURE IP20

List No	A	B	C	D	E
844/4	223	112	66	184	73

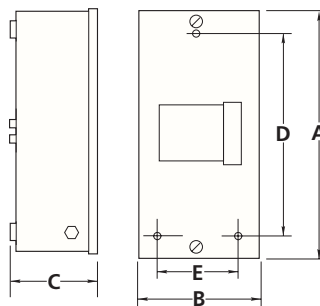

APPROXIMATE DIMENSIONS (mm)

TIME SWITCHES

LIST No	A	B	C	D	E	F	G	H	J	K	L
Analogue											
303/TS24	90	54	66	45	60	46	-	-	-	-	-
303/TQ24	90	54	66	45	60	46	-	-	-	-	-
303/TQ7	90	54	66	45	60	46	-	-	-	-	-
Digital											
302/TD1	86	36	66	45	60	40	-	-	-	-	-
302/TD2	86	36	66	45	60	40	-	-	-	-	-
Staircase											
301/S7	84	18	70	45	60	43	25	-	-	-	-

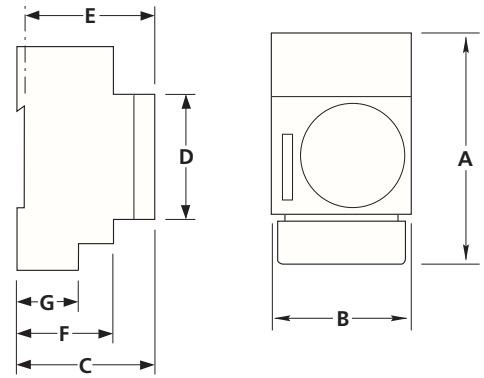

BELL TRANSFORMER

LIST No	A	B	C	D	E	F	G	H	J	K	L
303/B12	85	36	65	45	58	50	-	-	-	-	-
301/B6, B8, & B12	90	17.5	70	45	64	51	-	-	-	-	-

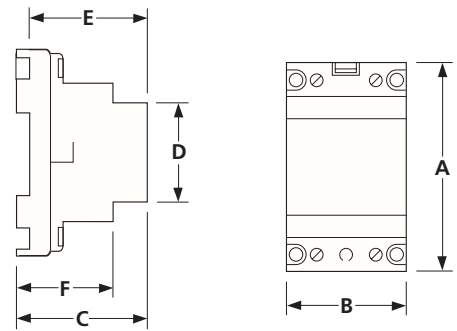

CONTACTORS & IMPULSE RELAYS

LIST No	A	B	C	D	E	F
CIK22-20	84	17.5	65.5	45	60	48.5
CIK24-30	84	35	65.5	45	60	48.5
CIK24-40	84	35	65.5	45	60	48.5
CIK40-20	84	53.5	65.5	45	60	48.5
CIK40-30	84	53.5	65.5	45	60	48.5
CIK63-31	84	53.5	65.5	45	60	48.5
CIK63-40	84	53.5	65.5	45	60	48.5

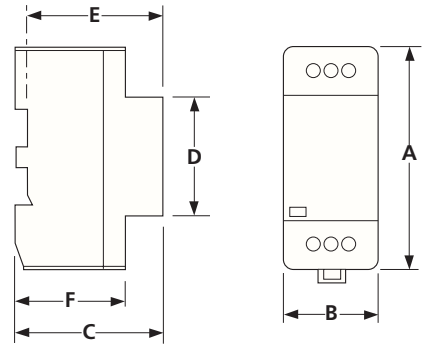

TWILIGHT SWITCH

LIST No	A	B	C	D	E	F	G	H	J	K	L
303/P2	86	54	66	45	60	46	116	61	27	25	-

